

SUSPENSION - XENON 3.0 L / 2.2 L DICOR



- 'R' and 'L' are marked at one end of RH and LH torsion bars respectively. Install unmarked end of torsion bar RH to the bracket on lower wishbone of RH side. Similarly install torsion bar LH. (Fig. 21)
- Assemble the levers on torsion bar at rear end, such that after putting one nut, 1 to 3 mm protrusion of the anchoring bolt is maintained.
- Tighten nut up to approx. 68 mm. protrusion of anchor bolt. Fit lock nut and tighten it.
- Remove jack. Bounce the wheel to settle suspension.
- Measure front chassis height from the ground. If it is not 550 ± 3 mm. adjust it by torsion bar anchoring bolt.

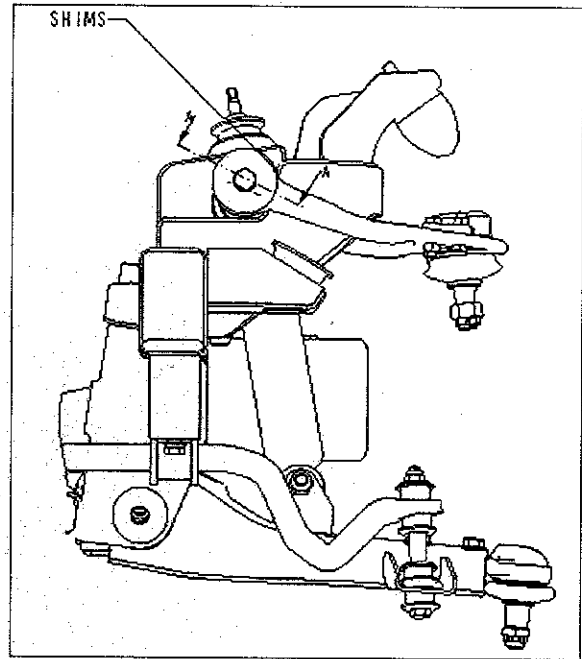

Fig. 20 - Lower wishbone height adjustment

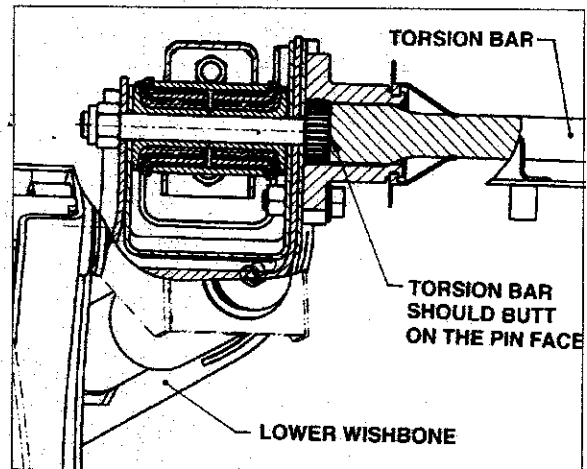

Fig. 21 - Installation of torsion bar