

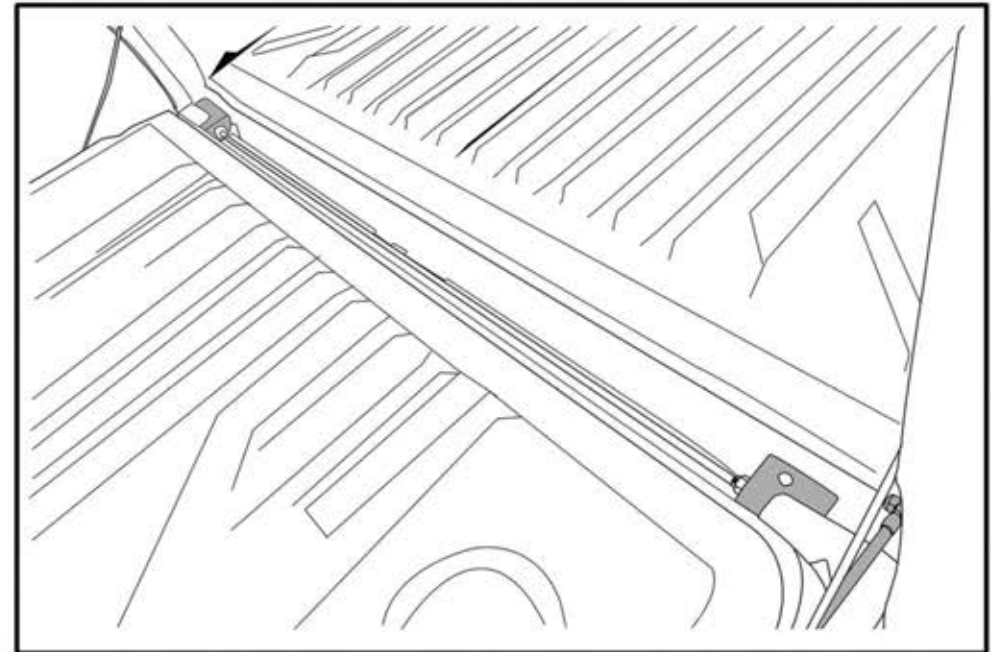

## FITTING INSTRUCTION

### FORD T6



## Note :

Apply WD40 or grease to the moving parts regularly for good performance of the product.

Patent Pending Worldwide

Patent Pending Worldwide

**Part list**

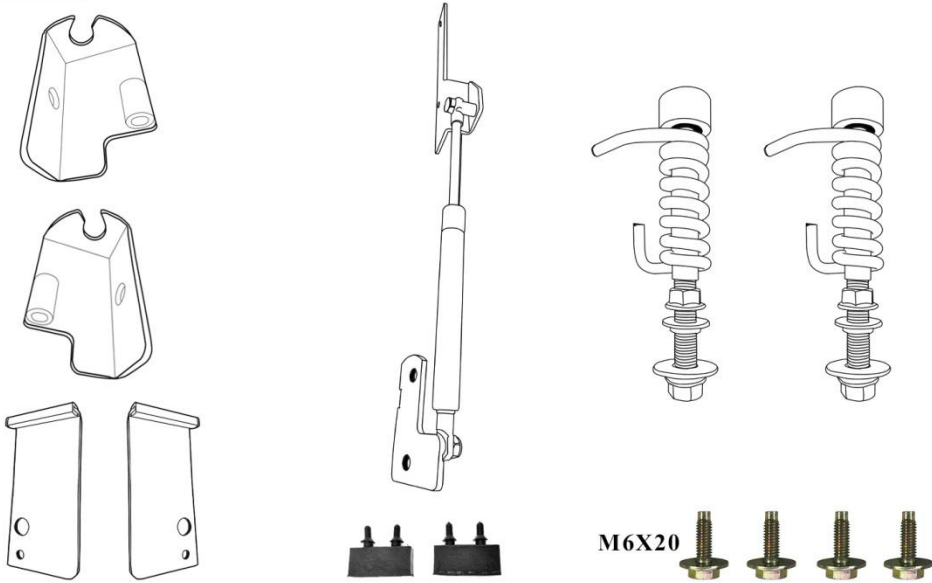

**Tooling**

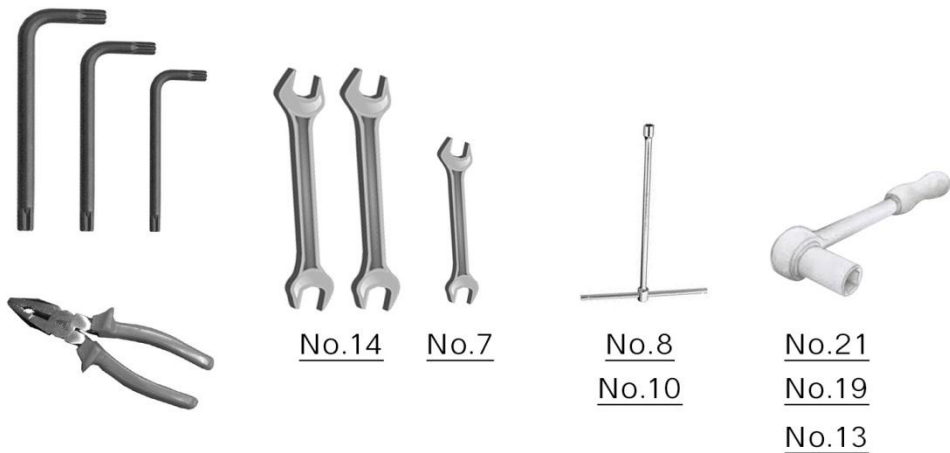

**CAUTION**

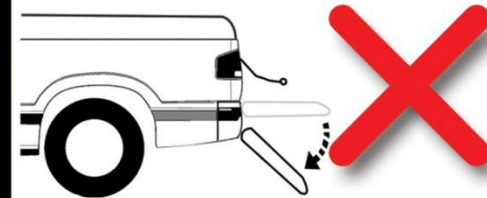

Do not take off  
tailgate cable  
and drop down  
the tailgate

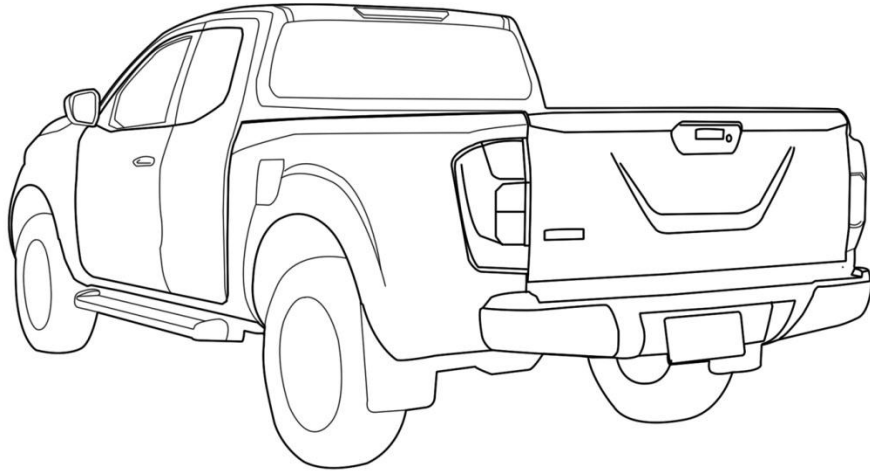

9.put back rear bumper

**NOTE : Process #2 - #4 will  
be done from the bottom of  
the tailgate while the tailgate  
in closed position.**

**1. take off rear bumper**

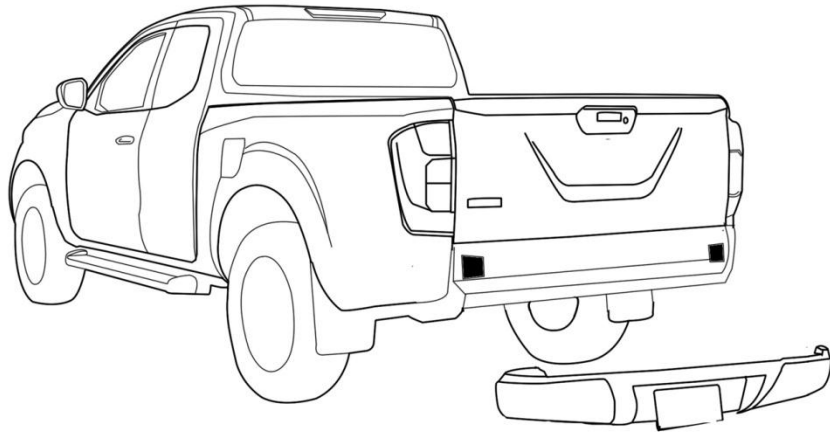

**2. un-bolt the truck tailgate bracket**

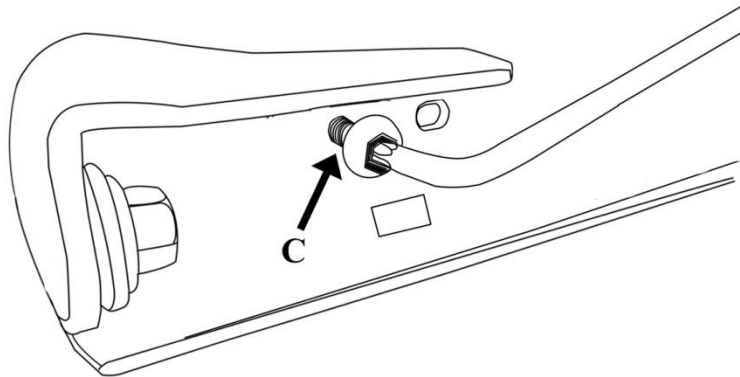

**7. Attach damper to the tailgate by putting damper bracket (T) under tailgate sling bracket (U) and tighten together with original bolt (V) (W)**

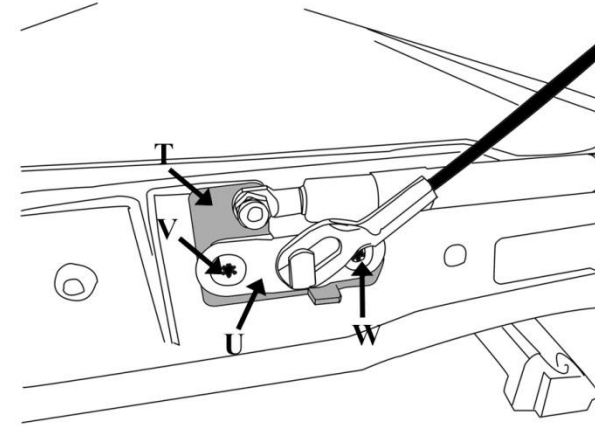

**8. Put stopper rubber with tailgate bracket**

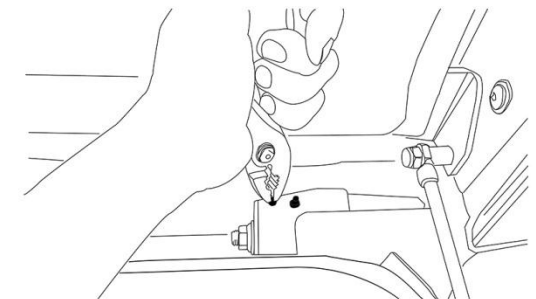
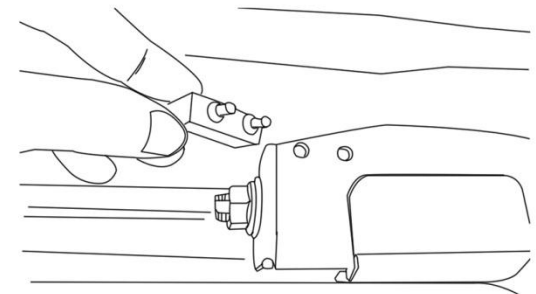

5. Attache spring pushing bracket (O) with the truck using original bolt (P). If the truck has stopping rubber, can put it back through hole (Q)

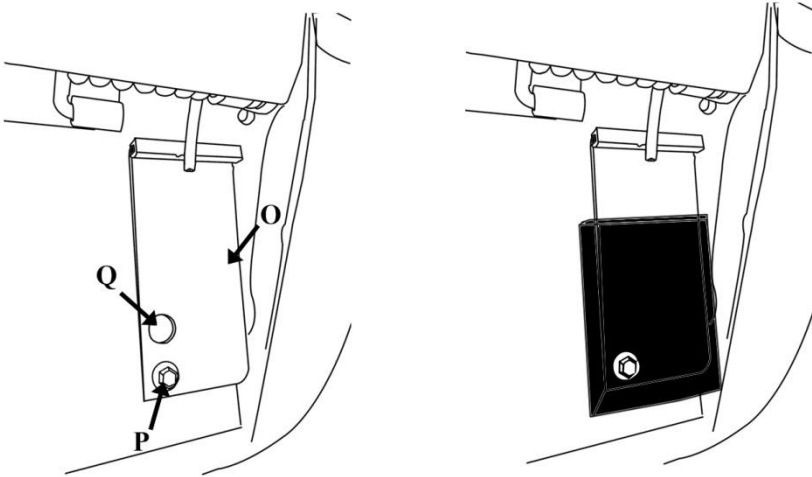

6. Attache damper to the truck using original bolt (R) (S)

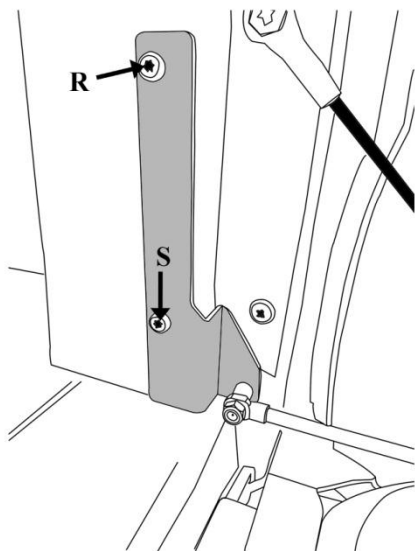

3. Attache tailgate bracket (A) on the truck tailgate bracket (B) using original bolt(C)

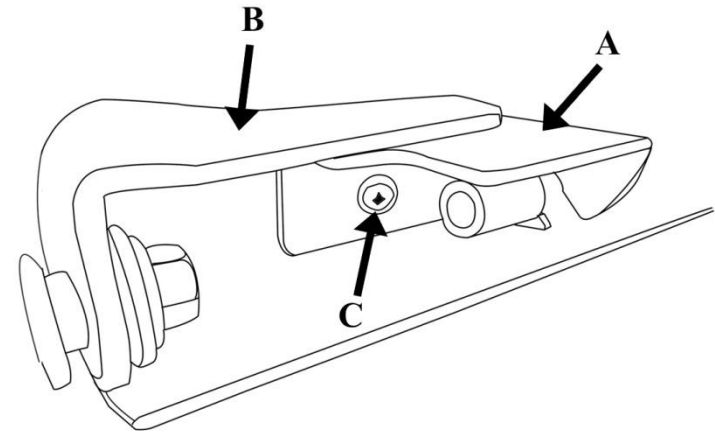

4. Assembly the spring set with tailgate bracket

4.1 put spring set with tailgate bracket as below picture

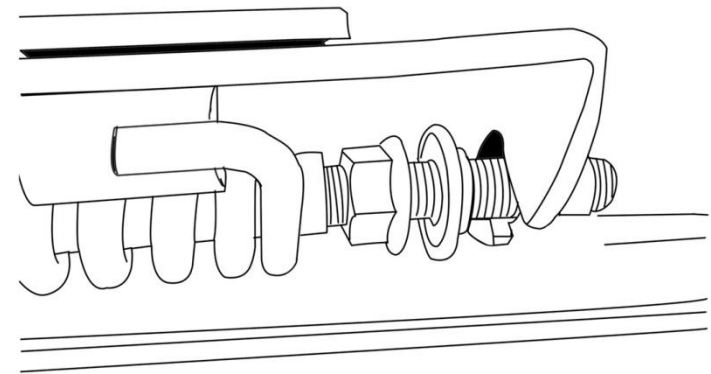

4.2 put flange (D) to the hole on tailgate bracket as below picture

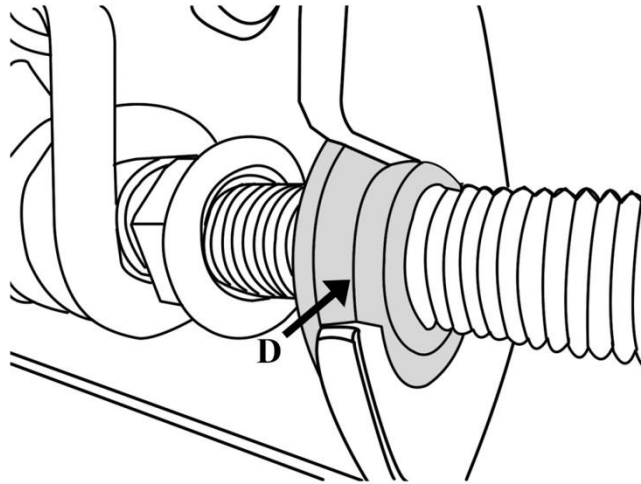

4.3 tighten nut (E) while holding the rod of the spring set with #7 wrench (F)

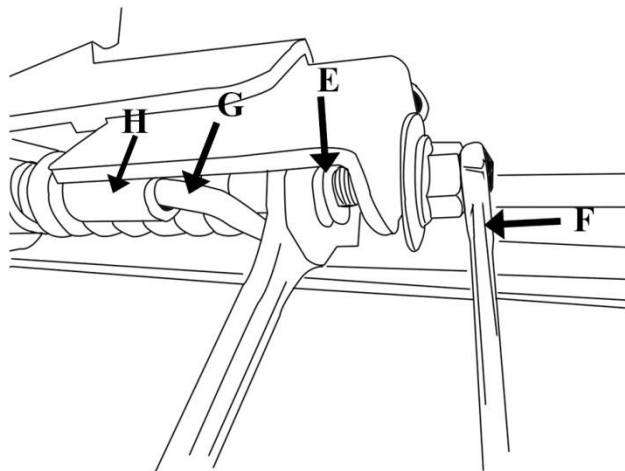

Make sure that the spring end (G) is slided in the bush (H) of the tailgate bracket

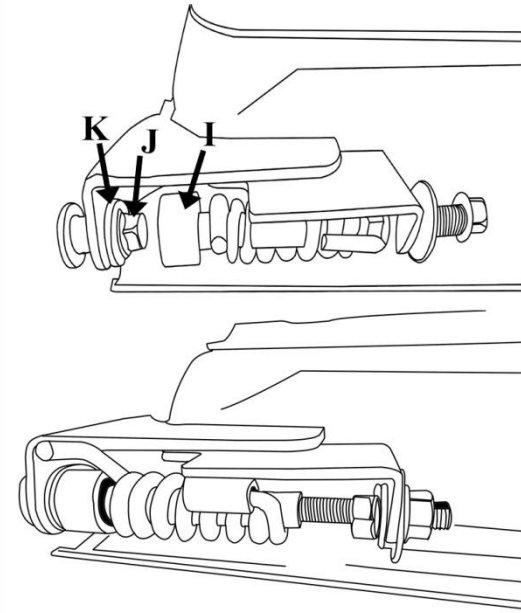

tighten the nut (E) till bush (I) completely cover the bolt head (J) and touch the flat washer (K)

4.4 tighten nut (L) with wrench #14 (M) while holding nut (E) with wrench #14 (N)

